



**BBQ GURU CYBERQII USER GUIDE Rev. 1.00 for v1.05 Firmware**



1. DESCRIPTION.....	4
2. BBQ GURU CYBERQII Features.....	4
3. CONTROLLER CONNECTIONS.....	4
4. KEYS.....	4
5. POWERING UP.....	5
5.1. Startup Screen.....	5
6. STANDARD DISPLAY SCREENS.....	5
6.1. Main Display Screen.....	5
6.2. Pit 1 Setpoint Display Screen.....	6
6.3. Pit 1 Ramp Display Screen.....	6
6.4. Pit 2 Setpoint Display Screen.....	6
6.5. Pit 2 Ramp Display Screen.....	6
7. BATTERY, BACKLIGHT, BEEPER AND DISPLAY SETUP.....	6
7.1. Battery Power Display Screen.....	7
7.2. Backlight Intensity Set Screen.....	7
7.3. Backlight Time Set Screen.....	7
7.4. Contrast Set Screen.....	7
7.5. Alarm and Key Beeps Set Screen.....	7
8. PIT 1 USER SETUP SCREENS.....	8
8.1. Fan 1 Percentage Display Screen.....	8
8.2. Pit 1 Set Screen.....	8
8.3. Pit 1 Hold Set Screen.....	8
8.4. Food 1 Set Screen.....	8
8.5. Timer 1 Set Screen.....	8
8.6. Timeout Action 1 Set Screen.....	9
8.7. Alarms 1 Set Screen.....	9
8.8. Ramp 1 Set Screen.....	9
8.8.1. Ramp Feature Description.....	9
8.9. Open Lid Detect 1 Set Screen.....	10
8.9.1. Open Lid Detect Description.....	10
8.9.2. Open Lid Detect – Overshoot Eliminator.....	11
9. PIT 2 USER SETUP SCREENS.....	11
10. SUPER USER MENU.....	11
10.1. Proportional Band Screen.....	12
10.2. Ramp Offset Screen.....	12
10.3. Cycle Time Screen.....	12
10.4. Deviation Alarm Screen.....	12
10.4.1. Alarm Deviation Setpoint.....	13
10.5. Temperature Units Screen.....	13
10.6. Reset All Screen.....	14
11. STATUS SCREENS.....	14
11.1. Food Done Alarm.....	14
11.2. Pit Temp High Alarm.....	14
11.3. Pit Temp Low Alarm.....	14

11.4. Timeout No Action .....	14
11.5. Timeout Alarm.....	15
11.6. Timeout Shutdown.....	15
11.7. Timeout Hold.....	15
11.8. Temperature Error Messages .....	15
11.9. Zero Adjust Screen .....	16
11.10. Span Adjust Screen.....	16
11.11. Calibrating The Zero (Low end temperature).....	16
11.12. Calibrating The Span (High end temperature).....	17
12. ADAPTIVE CONTROL STRATEGY.....	17
13. BUILDING A PROPER FIRE FOR GOOD CONTROL .....	17
13.1. Eliminating Large Fluctuations in the Pit Temperature.....	17
13.2. To Extinguish The Pit.....	18
14. DEFINITION OF TERMS .....	18
15. FLOW DIAGRAM OF STANDARD DISPLAY SCREENS.....	19
16. FLOW DIAGRAM OF USER SETUP SCREENS .....	20
17. FLOW DIAGRAM OF SUPER USER MENU.....	21

**Important Note:** This User Guide refers to the operation of the CyberQII control unit only (hardware). For information of the CyberQII Control Interface PC application, please refer to its User Guide.

## 1. DESCRIPTION

The CYBERQII is the most advanced BBQ control on the planet. It is called the CYBERQII because it can be accessed through cyber space from a remote location via its USB interface and its Control Interface PC application. This awesome control is actually two controls – it can be used to control two pits. Just check out some of the features listed below.

## 2. BBQ GURU CYBERQII Features

- Super compact control allows you to control up to two pits simultaneously
- Four thermocouple probes allow you to monitor two pits and two food items
- USB interface allows monitoring and control from your PC or over the Internet
- Digital alphanumeric 8 character x 2 line LCD display with user-selectable backlight time
- Audible alarm sounds on over/under temp, food done, timeout and other user-settable conditions
- Real-time fan status and percent output indication helps you to measure fuel use
- Open Lid Detect
- Adaptive Control Algorithm
- Super User menu for advanced users
- User-settable “low and slow” ramp down feature
- User-settable cook timer gives alarm, shuts down your pit, or will hold the pit at the temperature you specify
- Battery power indicator
- Adjustable proportional band, cycle time, and deviation alarms (Super User menu)
- Display temperature in degrees C or F
- Alarms settable to on or off (good neighbor feature)
- Adjustable display contrast
- 32 to 475 deg F range with +/- 2 deg F accuracy

## 3. CONTROLLER CONNECTIONS

From left to right:

USB, Pit 1, Food 1, Pit 2, Food 2, Fan Output 1, Fan Output 2, 12V Power Input



## 4. KEYS

UP  - Indexes the shown value up. Also returns you to the previous display menu.



DOWN  - Indexes the shown value down. Also indexes you through the display menu.

**ON/OFF**  - Powers the unit up and down. Must be held down for 2 seconds to power on/off.

**SCROLL**  - Indexes you through all setup menus.

**UP + DOWN**  +  - Returns you to the main display screen from *any* screen.

**UP + SCROLL**  +  - Takes you to the main Super User menu.

**DOWN + SCROLL**  +  - Returns you to the main display screen from the Super User menu.

## 5. POWERING UP

Pressing the ON / OFF  key will power up the control. On power up the unit shows the Startup screen:

### 5.1. Startup Screen

The display will show the startup screen for approximately 2 seconds and then will show the Main Display Screen:

C	Y	B	E	R	Q	2
1.	0	5		1	0	0

In the above example, the version number is 1.05 and the serial number is 100.

## 6. STANDARD DISPLAY SCREENS

There are five different ways to display the temperatures, setpoints and status as described below. Navigate through them using the down  key. See the FLOW DIAGRAM OF STANDARD DISPLAY SCREENS at the end of this document.

### 6.1. Main Display Screen

P <sub>1</sub>	2	5	0	F <sub>1</sub>	1	8	1
P <sub>2</sub>	2	2	5	F <sub>2</sub>	1	6	9

In this example, the top row shows the actual temperature (250) of pit 1 (P<sub>1</sub>) and the actual temperature (181) of the food (F<sub>1</sub>) within pit 1.

The bottom row shows the actual temperature (225) of pit 2 (P<sub>2</sub>) and the actual temperature (169) of the food (F<sub>2</sub>) within pit 2.

Dashes (---) will be displayed if no probe is plugged into the associated connector.

### 6.2.Pit 1 Setpoint Display Screen

P <sub>1</sub>	2	5	1	*	2	5	0
F <sub>1</sub>	1	7	9	S <sub>P</sub>	1	8	0

This display screen shows the actual and set temperatures for pit 1 (P<sub>1</sub>) and its food (F<sub>1</sub>).

On the top row: the leftmost digits are the actual pit temperature (P<sub>1</sub>). Dashes (---) will be displayed if no probe is plugged into the associated connector. An \* will be displayed if the fan is running. The rightmost digits are the setpoint of pit 1.

On the bottom row: the leftmost digits are the actual food temperature (F<sub>1</sub>). Dashes (---) will be displayed if no probe is plugged into the associated connector. “SP” indicates setpoint. The rightmost digits are the setpoint of the Food 1.

### 6.3.Pit 1 Ramp Display Screen

P1	2	5	1	F1	1	7	9
0	0	:	0	0		R	0

This display screen shows the actual temperatures of pit 1 (P<sub>1</sub>) and its food (F<sub>1</sub>). Dashes (---) will be displayed if no probe is plugged into the associated connector.

The bottom row displays the cook timer. “R” indicates ramp mode is turned on and currently active. “r” indicates ramp mode is turned on but not active. The percentage of the fan running time is displayed as values 0 – 9, and “F” for full or 100%. An \* will be displayed if the fan is running.

### 6.4.Pit 2 Setpoint Display Screen

P <sub>2</sub>	2	2	6	*	2	2	5
F <sub>2</sub>	1	6	9	S <sub>P</sub>	1	7	0



This display screen is identical to the screen described in section Pit 1 Setpoint Display Screen, but for pit 2 (P<sub>2</sub>).

### 6.5.Pit 2 Ramp Display Screen

P <sub>2</sub>	2	5	1	F <sub>2</sub>	1	6	9
0	0	:	0	0		R	0

This display screen is identical to the screen described in section Pit 1 Ramp Display Screen, but for pit 2 (P<sub>2</sub>).

## 7. BATTERY, BACKLIGHT, BEEPER AND DISPLAY SETUP

The following screens are accessible by pressing the scroll  key from the Main Display Screen. Use the scroll  key to move through the screens. Use the  &

 keys to set the values. Moving to another screen saves your chosen value. (See the FLOW DIAGRAM OF USER SETUP SCREENS at the end of this document).



### 7.1. Battery Power Display Screen

B	A	T	T	P	W	R
8	5	%				

This screen displays the battery level (or the wall adaptor) in %, where 85% ~ 12VDC and 100% ~ 14VDC. The Batter Power is useful mainly when powering from external batteries or an automotive power source.



### 7.2. Backlight Intensity Set Screen

B	A	C	K	L	I	T	E
	5	0	%				

This screen allows you to set the backlight intensity from 0-100%. Use the  &  keys to set to the desired intensity. Default value is 50%.



### 7.3. Backlight Time Set Screen

B	A	C	K	L	I	T	E
5	S	E	C				

This screen allows you to set the backlight timer. Set from: OFF, 1, 5, 10 (seconds), ON. Use the  &  keys to set the desired time (ON = energized constantly). Default value is 5.

### 7.4. Contrast Set Screen

C	O	N	T	R	A	S	T
6	0	%					

This screen allows you to set the contrast by using the  &  keys. Default value is 60%.





### 7.5. Alarm and Key Beeps Set Screen

A	L	A	R	M,	K	E	Y
	B	E	E	P	S	3	

This screen allows you to set the alarm from 5 beeps to 0. If set to 0, the unit will not beep when a key is pressed, nor will it beep for an alarm. If set from 1 to 5, it will beep once when a key is pressed, and the number it is set to for an alarm. Use the  &

▼ keys to set the desired number of beeps. This feature is useful to help distinguish your control's alarms from other nearby controls. Default value is 3.

## 8.PIT 1 USER SETUP SCREENS

The following screens are accessible by pressing the scroll  key from the Pit 1 Setpoint Display Screen, as well as from the Pit 1 Ramp Display Screen. Use the scroll  key to move through the screens. Use the  &  keys to set the values. Moving to another screen saves your chosen value. (See the FLOW DIAGRAM OF USER SETUP SCREENS at the end of this document).



### 8.1.Fan 1 Percentage Display Screen

F	A	N <sub>1</sub>	P	C	T
5	0	%			

This screen displays the fan output percentage from 0-100%. This screen is useful to determine the fuel level. If the fan is running 80% - 90% or more during the middle or end of a cook, it may be time to add more charcoal.

### 8.2.Pit 1 Set Screen

P	I	T <sub>1</sub>	S	E	T
2	5	0			

The temperature can be set from 32 to 475 degrees F using the  &  keys. Default value is 275.



### 8.3.Pit 1 Hold Set Screen

P	I	T <sub>1</sub>	H	O	L	D
2	0	0				

Pit 1 Hold is the temperature at which Pit 1 will be held if the Timeout Action is set to Hold. Temperatures range from 32 to 475 degrees F. Default value is 200.

### 8.4.Food 1 Set Screen

F	O	O	D <sub>1</sub>	S	E	T
1	8	5				

The temperature can be set from 32 to 210 degrees F using the  &  keys. Default value is 185.

### 8.5.Timer 1 Set Screen

T	I	M	E	R <sub>1</sub>
---	---	---	---	----------------

0 0 : 0 0



The maximum value is 99:59, use the  &  keys to change the value. Default value is 00:00.

### 8.6.Timeout Action 1 Set Screen

T I M E O U T<sub>1</sub>  
N O A C T ' N



Options for the Timeout function are:

- **NO ACT'N:** do nothing when the set timer expires.
- **ALARM:** sound an alarm when the set timer expires.
- **SHUTDOWN:** shut down the fan when the set timer expires.
- **HOLD:** hold pit 1's temperature to the value set on the "Pit 1 Hold Set Screen" when the set timer expires.

The default setting is NO ACT'N; Use the  &  keys to change the value.



### 8.7.Alarms 1 Set Screen

A L A R M S<sub>1</sub>  
O N

Values are OFF and ON. The temperature values for the alarms are setup in the Super User Menu. The default setting is ON; Use the  &  keys to change the value.

### 8.8.Ramp 1 Set Screen

R A M P<sub>1</sub>  
O F F

Values are OFF and ON. The default setting is OFF; use the  &  keys to change the value.

#### 8.8.1. Ramp Feature Description

When the ramp is set to ON, the "low and slow" ramp mode is enabled. This mode is used for slow cooks so your food (meat) never over-cooks. Ramp mode is a very helpful feature in preventing overcooking. The fan will control the pit temperature as follows: the pit temperature will rise or remain steady as needed as the food temperature starts to rise. But as the food temperature nears its set point, the fan will control the pit so that the pit temperature will fall. Specifically this feature will gradually lower the pit temperature toward the food set point temperature when the food is within 30° of being done. The controller will hold the pit temperature slightly above your food set point as long as there

is fuel. This feature is similar to cook and hold, but the control calculates everything for you.

The factory default setting is OFF so you must enable this feature to use it. Note when using this feature, you may want to start your pit temperature a little higher than normal to reduce cook time and not overcook your food. If the food probe is not plugged in and the ramp mode is turned on, the ramp led will show steady (ramp mode is turned on) but no ramping will take place.

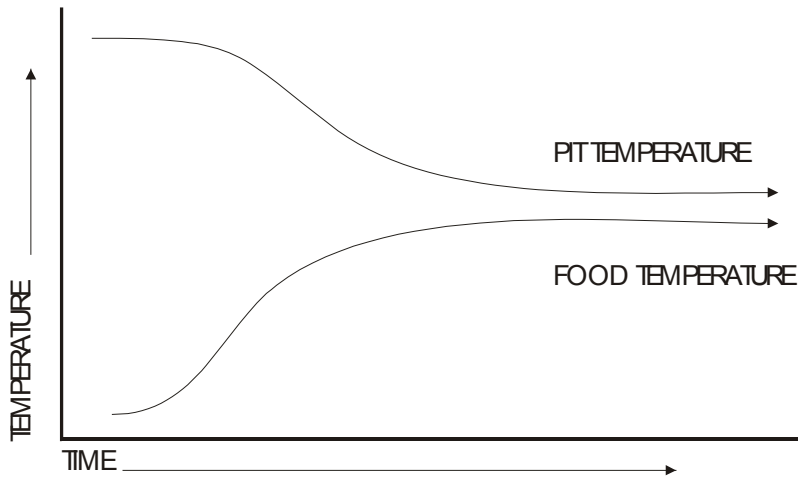

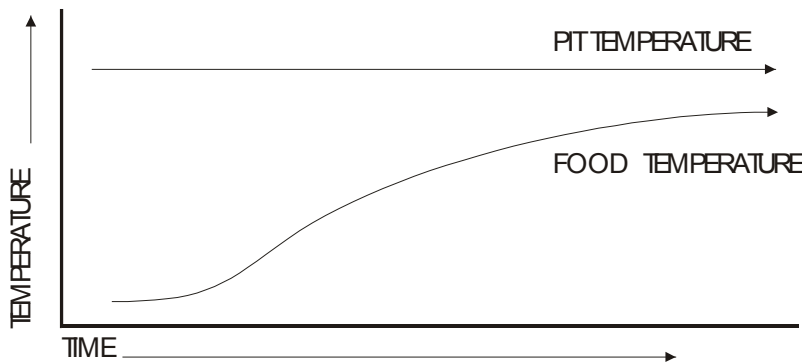

**8.8.1.1.Ramp = ON Response Plot**



**8.8.1.2.Ramp = OFF Response Plot**

## 8.9.Open Lid Detect 1 Set Screen

L	I	D <sub>1</sub>	O	P	E	N
O	F	F				

Values are OFF and ON. The default setting is OFF; use the  &  keys to change the value.

### 8.9.1. Open Lid Detect Description

This feature will allow quick recovery to the setpoint temperature after you open your lid. When the Open Lid Detect is set to ON, the feature is enabled. When you open your pit's

lid, the temperature will drop. This can cause the blower to over-fire the coals and cause overshoot when the lid is shut. This mode detects when the pit's lid is open and minimizes the blower running during that time. Some overshoot will always be present when your pit's lid is opened and closed even if the blower is off, because it still introduces oxygen to the fire. This prevents the low alarm erroneously sounding when the temperature drops and the lid is open. The factory default is ON, so you must disable this feature if you have problems with excess air currents in your pit. To disable this feature set it to OFF.

### 8.9.2. Open Lid Detect – Overshoot Eliminator

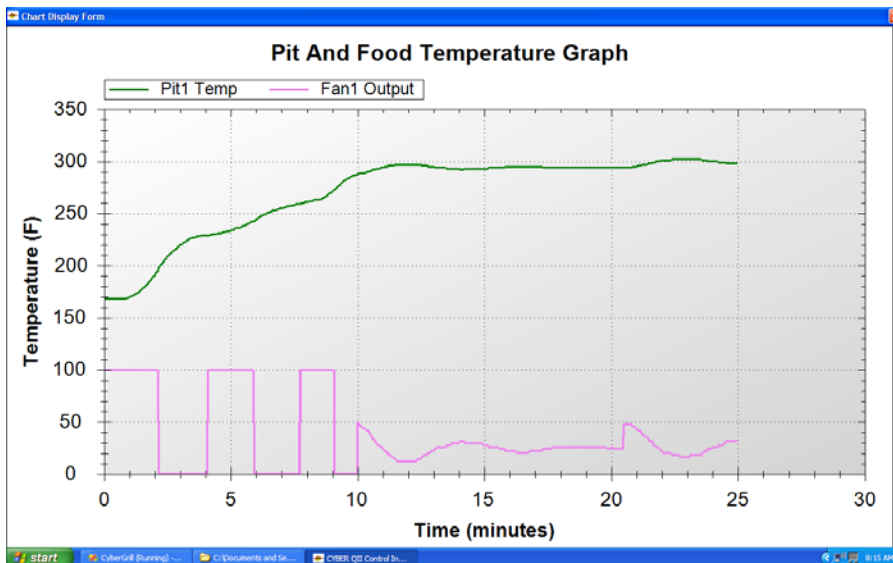

When the Open Lid Detect is enabled, the rate of temperature rise of your pit will be limited preventing over-firing. This will make a typical startup to a temperature of 250 deg F take a minimum of about 20 minutes and will help to eliminate startup overshoot.

Take note in the chart below how the output is cycled on the approach to the setpoint of 300 deg. This minimizes the setpoint overshoot on startup.







## 9.PIT 2 USER SETUP SCREENS

Every screen described above under Pit 1 User Setup Screens sections is duplicated for Pit 2.



The Pit 2 screens are accessible by pressing the scroll  key from the Pit 2 Setpoint Display Screen, as well as from the Pit 2 Ramp Display Screen. Use the scroll key to move through the screens. Use the  &  keys to set the values. Moving to another screen saves your chosen value. (See the FLOW DIAGRAM OF USER SETUP SCREENS at the end of this document).

## 10.SUPER USER MENU

Press the up and scroll  &  keys to enter the Super User Menu.

Press the up and down  &  or down and scroll  &  keys to exit the Super User Menu and return to the Main Display Screen. (See the FLOW DIAGRAM OF SUPER USER MENU at the end of this document).

The screens are shown in the order they appear as the scroll  key is pressed. When the Reset All screen is reached and the scroll key is pressed again the menu system will return to the Main Display Screen.

Use the  &  keys to set the values. Moving to another screen saves your chosen value.

If the unit is left showing any screen for more than 10 seconds, it will revert to the Main Display Screen.

### 10.1. Proportional Band Screen

P	R	O	P	B	A	N	D
2	5		D	E	G		

The advanced user can adjust the Proportional Band from 1- 99 deg F. The default value is 25 deg F. For clarification of this feature see the definition of terms section at the end of this manual.

### 10.2. Ramp Offset Screen

R	M	P	O	F	F	S	T
3	0		D	E	G		

The advanced user can adjust the Ramp Offset from 10-60 deg F. The default value is 30 deg F. This offset is used as follows: When the controller is in ramp mode the internal pit setpoint will be ramped down from the pit setpoint to the Food Setpoint + Ramp Offset. For clarification of this feature see the definition of terms section at the end of this manual.

### 10.3. Cycle Time Screen

C	Y	C		T	I	M	E
6			S	E	C		

The advanced user can adjust the cycle time from 4 to 10 seconds. The default value is 6 seconds. For clarification of this feature see the definition of terms section at the end of this manual.

### 10.4. Deviation Alarm Screen

A	L	A	R	M	D	E	V
5	0		D	E	G		

The advanced user can adjust the Deviation Alarm from 20 to 80 deg F. The default value is 50 deg F (50° above or below set temperature). The low deviation alarm is suppressed on startup, and will sound when the pit temperature is above or below the pit setpoint by this amount.

#### 10.4.1. Alarm Deviation Setpoint

If the temperature of the pit deviates above the setpoint by the alarm deviation setpoint, the alarm will sound and the display will blink “Pit Temp High!”.

If the temperature of the pit deviates below the setpoint by the alarm deviation setpoint, the alarm will sound and the display will blink “Pit Temp Low!”.

The low alarm will not sound when your control is first powered up and your pit is cold.

The alarm is only allowed once the temperature gets close to the pit temperature setpoint.

The alarm deviation is settable from 20 to 80 degF and the factory default is 50 degF.

If the ramp feature is turned on and the pit is actively ramping, the only time that the low alarm will become active is if the pit temperature drops 20 degrees F below the food (meat) setpoint temperature to let you know that something is wrong, for instance you are out of charcoal.

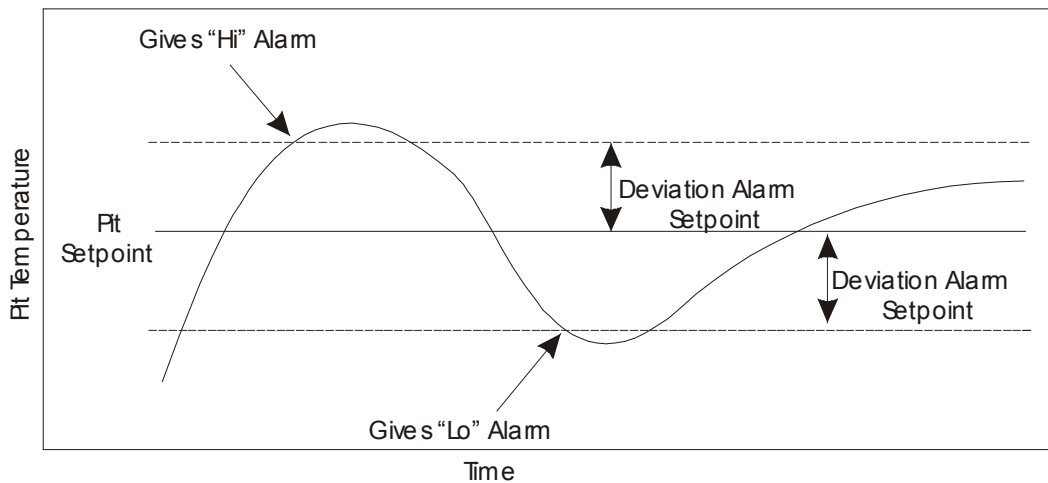

**10.4.1.1.Deviation Alarm Response Plot**

#### 10.5.Temperature Units Screen

T	E	M	P	U	N	I	T
F			D	E	G		

The advanced user can set the temperature units to F or C. Default setting is F. This affects all temperature displays and settings.

## 10.6.Reset All Screen

R E S E T A L L

The advanced user or technician can restore the factory defaults to all values programmed in the unit, including calibration.

When the up  key is pressed the display will show:

R E S E T A L L  
D O N E !

## 11.STATUS SCREENS

### 11.1.Food Done Alarm

F O O D<sub>1</sub>  
D O N E !

The Food Done alarm screen flashes when the Food temperature is greater than or equal to the Food setpoint. The beeper will sound if Alarms are set to ON. The Food 2 screen would be identical to the above.

### 11.2.Pit Temp High Alarm

P I T<sub>1</sub> T E M P  
H I G H !

The Pit Temp High alarm screen flashes when the pit temperature is greater than or equal to the pit setpoint + the deviation alarm value **50 deg F default** (50° above set temperature). The beeper will sound beeper if Alarms are set to ON. The Pit 2 screen would be identical to the above.

### 11.3.Pit Temp Low Alarm

P I T<sub>1</sub> T E M P  
L O W !

The Pit Temp Low alarm screen flashes when the pit temperature is less than or equal to the pit setpoint - the deviation alarm value **50 deg F default** (250° below set temperature). The beeper will sound beeper if Alarms are set to ON. The Pit 2 screen would be identical to the above.

### 11.4.Timeout No Action

T I M E O U T<sub>1</sub>



The Timeout No Action alarm screen flashes when the timer is expired and Timeout Action is set to No Action. The beeper is not sounded. The Timeout 2 screen would be identical to the above.

### 11.5.Timeout Alarm



The Timeout Alarm screen flashes when the timer is expired and Timeout Action is set to Alarm. The beeper will sound beeper if Alarms are set to ON. The Timeout 2 screen would be identical to the above.

### 11.6.Timeout Shutdown

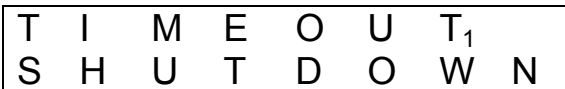

The Timeout Shutdown alarm screen flashes when the timer is expired and Timeout Action is set to Shutdown. The beeper will sound beeper if Alarms are set to ON. The Timeout 2 screen would be identical to the above. When this occurs, the corresponding setpoint will be set to 0 and it is likely that the corresponding Pit High Temp alarm will also display.

### 11.7.Timeout Hold

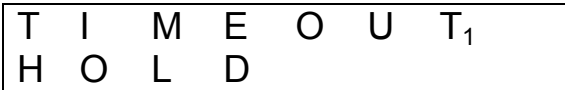

The Timeout Hold alarm screen flashes when the timer is expired and Timeout Action is set to Hold. The beeper will sound beeper if Alarms are set to ON. The Timeout 2 screen would be identical to the above. When this occurs, the corresponding setpoint will be set to the Hold setpoint and it is possible that the corresponding Pit High Temp alarm will also display.

### 11.8.Temperature Error Messages

Temperature Error messages are shown when the temperature is either too high or the probe is not plugged in. If the alarm key beeps are set to 0 no audible alarm will accompany them, otherwise the alarm will sound even if the alarms are set to off for Pit/Food 1 or 2. To clear this message and silence the alarm, press any key.

When the pit 1 temperature is over 475 deg F or the probe is unplugged the display will show the following. Pit 2 Temp Error message would be identical.

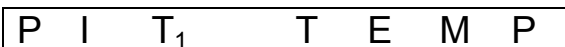

E	R	R	O	R
---	---	---	---	---

When the food1 temperature is over 475 deg F or the probe is unplugged the display will show the following. Food 2 Temp Error message would be identical.

F	O	O	D <sub>1</sub>	T	M	P
E	R	R	O	R		

### 11.9. Zero Adjust Screen

Using the ▲ & ▼ keys a factory technician or skilled user can adjust the zero calibration from -99 to +99. Zero calibration should be adjusted with an input of 32 degrees to the Food thermocouple input.

In the below example, the F1: 32 is the value the control thinks it is seeing on the Food 1 input. The +1 is the amount we are adding or subtracting from the reading to make it read correctly.

Z	E	R	O	A	D	J
+	1		F <sub>1</sub>	:	3	2

### 11.10. Span Adjust Screen

Using the ▲ & ▼ keys a factory technician or skilled user can adjust the span calibration from -99 to +99. Span calibration should be adjusted with an input of approximately 212 degrees to the Food thermocouple input.

In the below example, the F1: 212 is the value the control thinks it is seeing on the Food 1 input. The -4 is the amount we are adding or subtracting from the reading to make it read correctly.





S	P	A	N	A	D	J	
-	4		F <sub>1</sub>	:	2	1	2

### 11.11. Calibrating The Zero (Low end temperature)

1. Press and hold ▲ & ▼ and apply electrical power, continue to hold them down until the ZERO ADJ Screen is shown. Let the CyberQ warm up for about 15-20 minutes before proceeding.
2. The display will now show the adjustment amount and the temperature of the food 1 probe.
3. In a Styrofoam cup make an ice / water slurry using about 75% ice and 25% water. Fill it to the top with the slurry. Place the food probe into the bottom of the cup and stir it using the probe. Give the probe a couple of minutes to settle in the cup.
4. Adjust the value shown on the display to show 33 degrees F using the ▲ & ▼ keys. Remember that the display only updates every 3 seconds.

5. Proceed to Calibrating the Span by pressing the  key.

### 11.12. Calibrating The Span (High end temperature)

1. The display will now show the adjustment amount and the temperature of the food 1 probe.
2. Fill a second Styrofoam cup with some water that is at a rolling boil. Be careful not to get burned. Place the food probe into the bottom of the cup and stir it around gently. Give the probe a couple of minutes to settle in the cup.
3. Adjust the value shown on the display to show 211 degrees F using the  &  keys. Remember that the display only updates every 3 seconds.
4. Return to the Zero calibration by pressing the  key. And perform calibration according to Calibrating the Zero step # 3.
5. To exit the calibration, either power down by pressing the  key.

## 12. ADAPTIVE CONTROL STRATEGY

The CyberQII Adaptive Control Strategy is designed to operate with a wide variety of bbq pits by continually learning what your pit is doing and adapting to many factors such as outside air temperature, amount of charcoal, damper settings, etc. For the CyberQII to work properly and determine how to adapt, the temperature inside the pit cannot be oscillating up and down and the lid must stay closed. If you open the lid often, especially on startup, the control cannot be expected to maintain setpoint. If you leave the lid closed for approx 10-20 minutes, the temperature will become stable after the control adapts. If the lid has been shut for at least 20 -30 minutes and you notice the temperature going up and down significantly (+/- 10 degrees or more) the fan damper needs to be closed more; try ½ the current setting. Sometimes the Pit may run a few degrees high or low due to various conditions; don't sweat it, the control will bring it back to setpoint. Also remember that pit temperatures of 20 degrees high or low rarely have an affect on the quality of food.

## 13. BUILDING A PROPER FIRE FOR GOOD CONTROL

How you build the fire in your pit is critical for good control, especially at low temperatures. Stack the charcoal inside your pit so it's shaped like a pyramid, small at the top and large at the bottom. Light the fire by lighting a few coals at the top. Do not over-fire the charcoal or light it at the bottom, because this will only translate into startup overshoot and over-firing. Some overshoot is normal and it may take a while for the fire to stabilize.

### 13.1. Eliminating Large Fluctuations in the Pit Temperature

Normally the CyberQ will be able to adjust the airflow via the blower to deliver precise control and no damper adjustment will be required. If the pit has become over fired or if you built the fire too big, you may see large temperature swings (+/- 10 deg or more). To eliminate this you may need to restrict the airflow by adjusting the blower damper. A good rule of thumb is that if you see large temperature swings, try closing the damper to half the current setting; the pit should stabilize within 10-15 minutes after adjustment.

### 13.2. To Extinguish The Pit

If there is fuel left over from the cook, you can save this fuel by closing off any open dampers or removing the blower and plugging the inducer sleeve opening with a kill plug. This should put the fire out in about 30-45 min.

## 14. DEFINITION OF TERMS

**Proportional Band** – This value is the band of temperature over which the power draft fan will pulse. Say your internal pit setpoint is 225 (215 + 10 deg offset). Below 200 the power draft blower will be full on, above 225 the power draft blower will be full off and at 212.5 the power draft blower will cycle 50% of the time. The default value of 25 degrees will work well with most pits. If you notice that the pit temperature is oscillating up and down more than 5 to 10 degrees and never settles out, the proportional band can be made larger. Making the proportional band smaller will make the pit reach the setpoint faster, but will also increase the overshoot on startup. Each time you adjust the proportional band, expect that you will also need to adjust the offset to make the pit setpoint and actual temperature agree.

**Cycle Time** – This value is the time (in seconds) between power draft fan pulses. The default value of 6 seconds will work well with most pits.

**Ramp Offset** – When the ramp mode is turned on, the pit will be ramped down to the Food setpoint + the ramp offset when the Food temperature = the Food setpoint. The default value of 30 degrees will work well for most cuts of meat. For instance if your pit setpoint is 275 and your Food setpoint is 180, the pit will be ramped down to 210 (180+30) as your Food temperature climbs to 180. We determined the 30 degrees based on the amount of evaporative heat loss in an average piece of meat. If you make this lower the Food setpoint may never be achieved at the end of the ramp cycle due to the amount of evaporative heat loss. If you make this higher the Food setpoint may be slightly exceeded at the end of the ramp cycle.

# 15. FLOW DIAGRAM OF STANDARD DISPLAY SCREENS

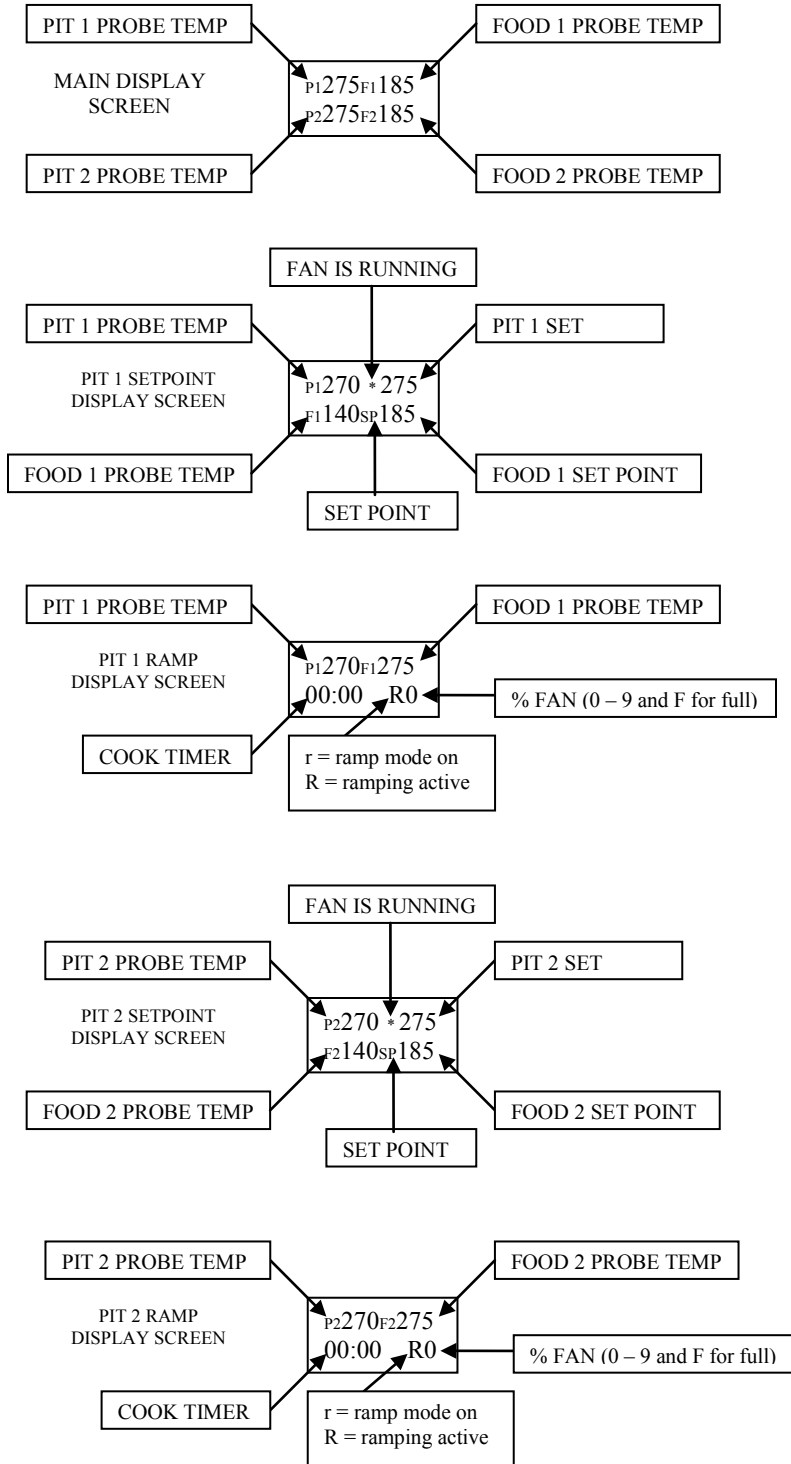

# 16. FLOW DIAGRAM OF USER SETUP SCREENS

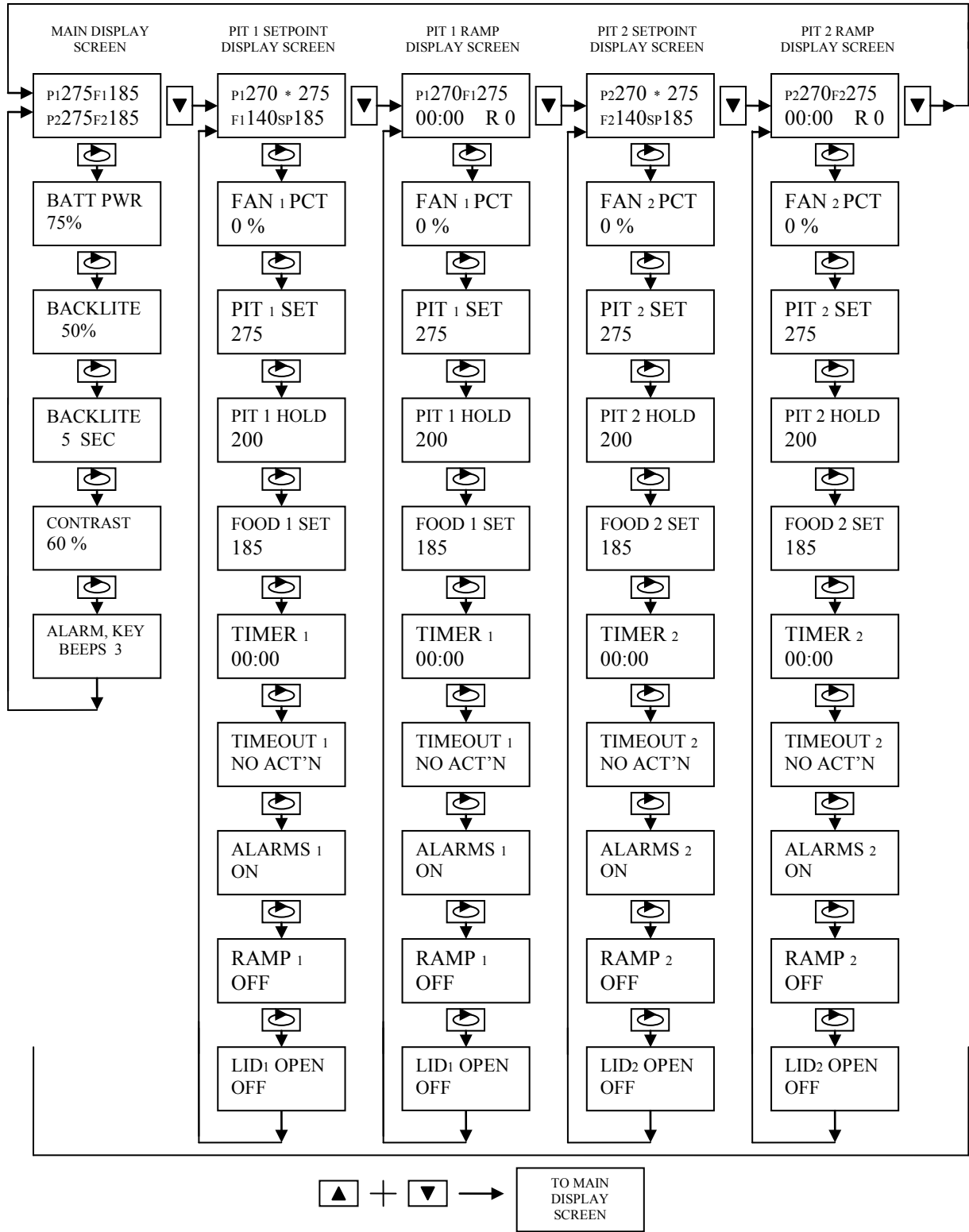

## 17. FLOW DIAGRAM OF SUPER USER MENU

